



HGS (INDIA) LIMITED



HGS-5517 Push Fit Array Connector



158, Sector-4, IMT Manesar, Gurugram-122050 Haryana INDIA
Tel: +91 (0124) 4681800, Fax: +91 (0124) 4681845
Email: sales@hgsindia.com



HGS (INDIA) LIMITED



SCHEMATIC

HGS-5517 Push Fit Array Connector

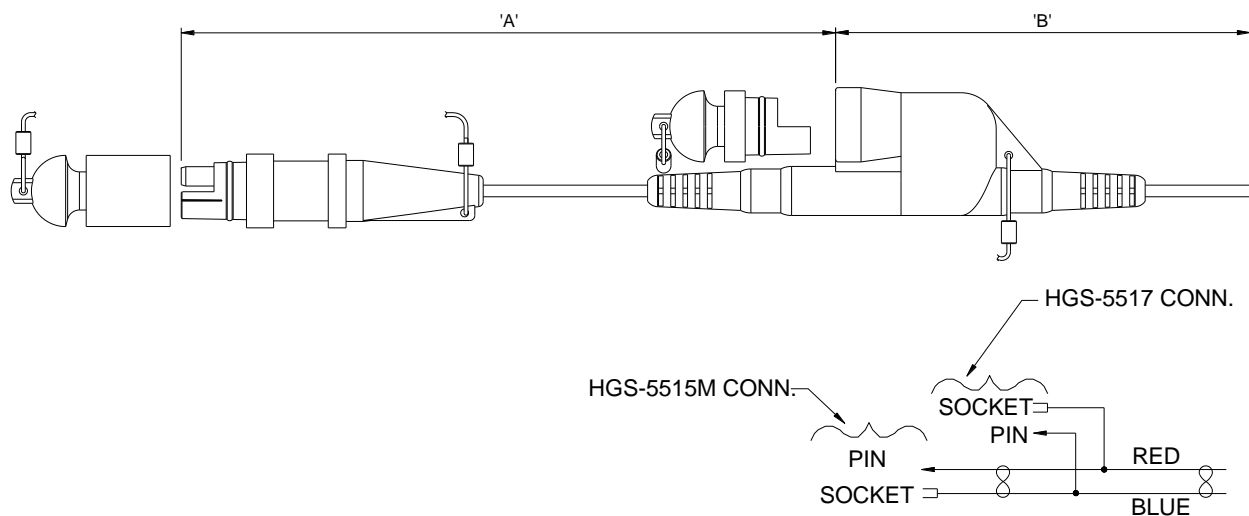

NOTE: LENGTH OF A & B TO BE AS PER CUSTOMER REQUIREMENT

WIRING DIAGRAM



HGS (INDIA) LIMITED



SPECIFICATIONS

HGS-5517 Push Fit Array Connector

- Connector with 5515 male push fit connector & 5517 female inline push fit connector.
- Impact Resistant Material.
- Moulded on 4.57, 5.33 or 6.35 mm cable.
- Water proof for marsh environment.
- Gold plated pins & sockets assure positive electrical connections.
- Maximum strength in rugged field condition.
- Fitted with dust cap.
- Operating Temperature Range: -20°C to +70°C.
- Water Pressure Rating: Up to 3 bar.

Version 1.1